



GRAPHIC DIVISION – PRODUCT DESCRIPTION	PG. 10.01
TABLE FOR PNEUMATIC PUMP SELECTION	PG. 10.02
SMALL PNEUMATIC SUCTION PUMPS item PA 3 and PA 7	PG. 10.03
SMALL PNEUMATIC SUCTION PUMPS item PA 10, PA 14 and PA 18	PG. 10.04
SMALL PNEUMATIC SUCTION PUMPS item PA 40, PA 70 and PA 100	PG. 10.05
SMALL PNEUMATIC SUCTION PUMPS item PA 140, PA 170 and PA 200	PG. 10.06
PNEUMATIC SUCTION PUMPS item PA 250 and PA 300	PG. 10.07
SMALL PNEUMATIC BLOWING PUMPS item PS 3 and PS 7	PG. 10.08
SMALL PNEUMATIC BLOWING PUMPS item PS 10, PS 14 and PS 18	PG. 10.09
SMALL PNEUMATIC BLOWING PUMPS item PS 40, PS 70 and PS 100	PG. 10.10
SMALL PNEUMATIC BLOWING PUMPS item PS 140, PS 170 and PS 200	PG. 10.11
PNEUMATIC BLOWING PUMPS item PS 250 and PS 300	PG. 10.12
SMALL COMBINED PNEUMATIC SUCTION PUMPS PA AND BLOWING PUMPS PS item PA 3 ÷ 7 WITH PS 3 ÷ 7	PG. 10.13
item PA 10 ÷ 18 WITH PS 10 ÷ 18	PG. 10.14
COMBINED PNEUMATIC SUCTION PUMPS PA AND BLOWING PUMPS PS item PA 40 ÷ 100 WITH PS 40 ÷ 100	PG. 10.15
item PA 140 ÷ 200 WITH PS 140 ÷ 200	PG. 10.16
item PA 250 ÷ 300 WITH PS 250 ÷ 300	PG. 10.17
SUCTION AND BLOWING SYSTEM AS	PG. 10.18
PNEUMATIC SUCTION AND BLOWING PUMP HOLDING SUPPORTS	PG. 10.19
PNEUMATIC SUCTION AND BLOWING PUMP SUCTION FILTERS	PG. 10.20
PNEUMATIC PUMP SPARE PARTS	PG. 10.21 ÷ 10.22
VACUUM CYLINDERS	PG. 10.23
DISC CUPS	PG. 10.24



The experience and production capacity of Vuototecnica has originated a division specially dedicated to the graphics and printing sector. A reference entity, ranging from engineering to services, that offers innovative and advantageous technical solutions under every point of view: performance, reliability, duration and operational economy. A significant demonstration of the Graphic Division specialisation is represented by the new range of products among which:

PNEUMATIC SUCTION AND BLOWING PUMPS

This new generation of highly versatile multiple-ejector pumps (multi-stage) are able to suction or blow as needed and represent a real evolution compared to conventional rotary vane pumps. Characterised by their new generation of ejectors, these pumps boast an excellent ratio between the quantity of air consumed and that suctioned (or generated), benefiting operational consumption. Their level of vacuum (or pressure level) and flow rate can be adjusted based simply on the air supply pressure. The state of the art hi-tech materials have considerably reduced the weight allowing them to be installed directly on the machine. The Vuototecnica research centre has focused its attention on noise reduction, with solutions that provide for full soundproofing and no moving parts, thus prolonging duration and eliminating any vibrations. Furthermore, these pumps are based on the Venturi principle which exploits the compressed air kinetic energy via in-line ejectors and, therefore, do not develop heat. The excellent filtration of the compressed air supply and intake air allows the intake of air free from oil, water condensates and impurities from between the sheets of paper to be separated in the working environment, with no pollution. Other assets of this safe and competitive technology include a minimal maintenance, limited to a regular filter cleaning operation, and reliability with no comparison. The pneumatic suction and blowing pumps are described in the following pages.

VACUUM CYLINDERS

By assembling a vacuum cup onto their perforated stem and creating a vacuum, the cup will quickly come into contact with the sheet or the object to be handled and it will automatically lift it, holding it until the vacuum is excluded. Thanks to all these features, this range of cylinders combined with cups are particularly recommended for separating sheets of paper or plastic. Advantages include: high speed operation, automatic compensation of the height of the objects to be lifted, non-rotating stems and extremely easy fixing. These vacuum cylinders are illustrated and described on the following pages.

VACUUM CUPS

These come in a large variety of shapes and sizes, to guarantee a quick and safe grip and they can be provided in anti-abrasion natural para rubber, nitrile or oil-resistant rubber, silicon, Viton, polyurethane and other compounds, according to the requirements. Vacuum cups are described in detail in Chapter 1. This chapter on the other hand will focus on disc cups only.



**Low air consumption and lightweight.
Surprising silence and total absence of heat.
Maximum respect for the work environment and minimum maintenance.**



TABLE FOR PNEUMATIC SUCTION PUMP SELECTION

Maximum suction flow rate generated by a corresponding electric pump	Maximum vacuum generated by a corresponding electric pump							
	-0.1 bar -10 KPa	-0.2 bar -20 KPa	-0.3 bar -30 KPa	-0.4 bar -40 KPa	-0.5 bar -50 KPa	-0.6 bar -60 KPa	-0.7 bar -70 KPa	-0.8 bar -80 KPa
10 m ³ /h	PA 40	PA 40	PA 40	PA 40	PA 40	PA 40	PA 40	PA 40
15 m ³ /h	PA 40	PA 40	PA 40	PA 40	PA 40	PA 40	PA 40	PA 70
20 m ³ /h	PA 40	PA 40	PA 40	PA 40	PA 40	PA 40	PA 70	PA 70
25 m ³ /h	PA 40	PA 40	PA 40	PA 40	PA 40	PA 70	PA 70	PA 70
30 m ³ /h	PA 40	PA 40	PA 40	PA 40	PA 70	PA 70	PA 70	PA 100
40 m ³ /h	PA 40	PA 70	PA 70	PA 70	PA 70	PA 100	PA 100	PA 140
60 m ³ /h	PA 70	PA 70	PA 70	PA 70	PA 100	PA 140	PA 140	PA 170
80 m ³ /h	PA 100	PA 100	PA 100	PA 100	PA 140	PA 140	PA 170	PA 200
100 m ³ /h	PA 100	PA 100	PA 100	PA 100	PA 140	PA 170	PA 200	PA 250
120 m ³ /h	PA 140	PA 140	PA 140	PA 140	PA 170	PA 200	PA 250	PA 300
140 m ³ /h	PA 140	PA 140	PA 140	PA 140	PA 200	PA 250	PA 300	-- --
160 m ³ /h	PA 170	PA 170	PA 170	PA 200	PA 250	PA 300	-- --	-- --
180 m ³ /h	PA 170	PA 170	PA 200	PA 250	PA 300	-- --	-- --	-- --
200 m ³ /h	PA 200	PA 200	PA 200	PA 250	PA 300	-- --	-- --	-- --
250 m ³ /h	PA 250	PA 300	PA 300	PA 300	-- --	-- --	-- --	-- --
300 m ³ /h	PA 300	PA 300	PA 300	-- --	-- --	-- --	-- --	-- --

Example: We need to replace an electric pump with a flow rate of 80 m³/h and a residual vacuum of -0.6 bar.

In the table, cross the "80 m³/h" line with the "-0.6 bar" column. At the intersection of the line with the column, you will find that PA 140 will be the ideal pump for replacement.

TABLE FOR PNEUMATIC BLOWING PUMP SELECTION

Maximum blowing flow rate generated by a corresponding electric pump	Maximum overpressure generated by a corresponding electric pump							
	0.1 bar 10 KPa	0.2 bar 20 KPa	0.3 bar 30 KPa	0.4 bar 40 KPa	0.5 bar 50 KPa	0.6 bar 60 KPa	0.7 bar 70 KPa	0.8 bar 80 KPa
25 m ³ /h	PS 40	PS 40	PS 40	PS 40	PS 40	PS 40	PS 40	PS 40
30 m ³ /h	PS 40	PS 40	PS 40	PS 40	PS 40	PS 40	PS 40	PS 40
40 m ³ /h	PS 40	PS 40	PS 40	PS 40	PS 40	PS 40	PS 40	PS 40
60 m ³ /h	PS 70	PS 70	PS 70	PS 70	PS 70	PS 70	PS 70	PS 70
80 m ³ /h	PS 70	PS 70	PS 70	PS 70	PS 70	PS 70	PS 70	PS 70
100 m ³ /h	PS 70	PS 70	PS 70	PS 70	PS 70	PS 70	PS 100	PS 100
120 m ³ /h	PS 100	PS 100	PS 100	PS 100	PS 100	PS 100	PS 100	PS 100
140 m ³ /h	PS 100	PS 100	PS 100	PS 100	PS 100	PS 100	PS 100	PS 140
160 m ³ /h	PS 140	PS 140	PS 140	PS 140	PS 140	PS 140	PS 140	PS 140
180 m ³ /h	PS 140	PS 140	PS 140	PS 140	PS 140	PS 140	PS 140	PS 140
200 m ³ /h	PS 140	PS 140	PS 140	PS 140	PS 140	PS 140	PS 170	PS 170
250 m ³ /h	PS 200	PS 200	PS 200	PS 200	PS 200	PS 250	PS 250	PS 250
300 m ³ /h	PS 250	PS 250	PS 250	PS 250	PS 250	PS 300	PS 300	PS 300
350 m ³ /h	PS 300	PS 300	PS 300	PS 300	PS 300	PS 300	PS 300	PS 300
400 m ³ /h	PS 300	PS 300	PS 300	PS 300	PS 300	PS 300	-- --	-- --

Example: We need to replace an electric pump with a flow rate of 80 m³/h and an overpressure of 0.6 bar.

In the table, cross the "80 m³/h" line with the "0.6 bar" column. At the intersection of the line with the column, you will find that PS 70 will be the ideal pump for replacement.



SMALL PNEUMATIC SUCTION PUMPS PA

The assembly of a pressure adjuster equipped with pressure gauge and of an FCL filter on the suction inlet connection of a vacuum generator of the M .. SSX range has allowed creating these small pneumatic suction pumps. Their main features include reduced overall dimensions compared to their technical performance.

The level of vacuum and flow rate can be adjusted according to the supply air pressure.

These pumps are powered with compressed air with a pressure ranging from 1 to 5 bar and they can produce a maximum vacuum of 85% and a suction flow rate between 2 and 18 m³/h, measured at a normal atmospheric pressure of 1013 mbar.

Based on the Venturi principle, they do not develop heat.

An SSX silencer screwed onto the pump exhaust ensures a silent operation.

The filter equipped with a microporous cartridge is located on the suction inlet connection and can keep the finest dust and impurities.

Thanks to their static operating principle, maintenance is reduced to only a simple regular cleaning of the filter.

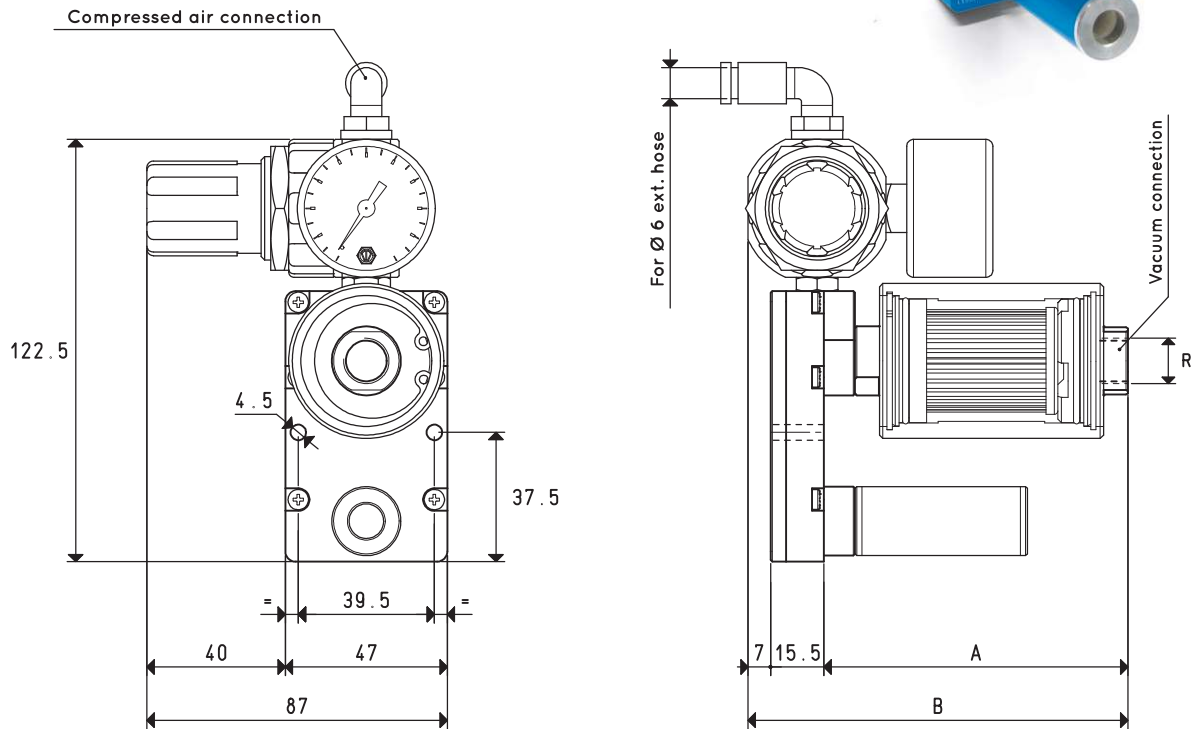

Item		PA 3				
Supply pressure	bar	1	2	3	4	5
Maximum level of vacuum	-KPa	20	42	62	80	85
Air consumption	NI/s	0.2	0.4	0.5	0.7	0.8
Intake air flow rate	m ³ /h	2.0	2.5	3.0	3.4	3.6
A				88		
B				110.5		
R	Ø			G1/4"		
Weight	Kg			0.45		
Item		PA 7				
Supply pressure	bar	1	2	3	4	5
Maximum level of vacuum	-KPa	20	42	62	80	85
Air consumption	NI/s	0.4	0.6	0.8	1.2	1.4
Intake air flow rate	m ³ /h	3.0	4.0	5.4	5.8	6.2
A				89		
B				111.5		
R				G3/8"		
Weight	Kg			0.46		
Operating temperature	°C	-20 / +80				

NOTE: All vacuum values indicated in the table are valid at the normal atmospheric pressure of 1013 mbar and obtained with a constant supply pressure.

Vacuum generator supply must be carried out with non-lubricated compressed air, 5 micron filtration, in accordance with standard ISO 8573-1 class 4.

Transformation ratio: N (newton) = Kg x 9.81 (force of gravity)

inch = $\frac{\text{mm}}{25.4}$; pounds = $\frac{\text{g}}{453.6} = \frac{\text{Kg}}{0.4536}$

Adapters for GAS - NPT threading available on page 1.130



SMALL PNEUMATIC SUCTION PUMPS PA 10, PA 14 and PA 18

3D drawings are available on vuototecnica.net

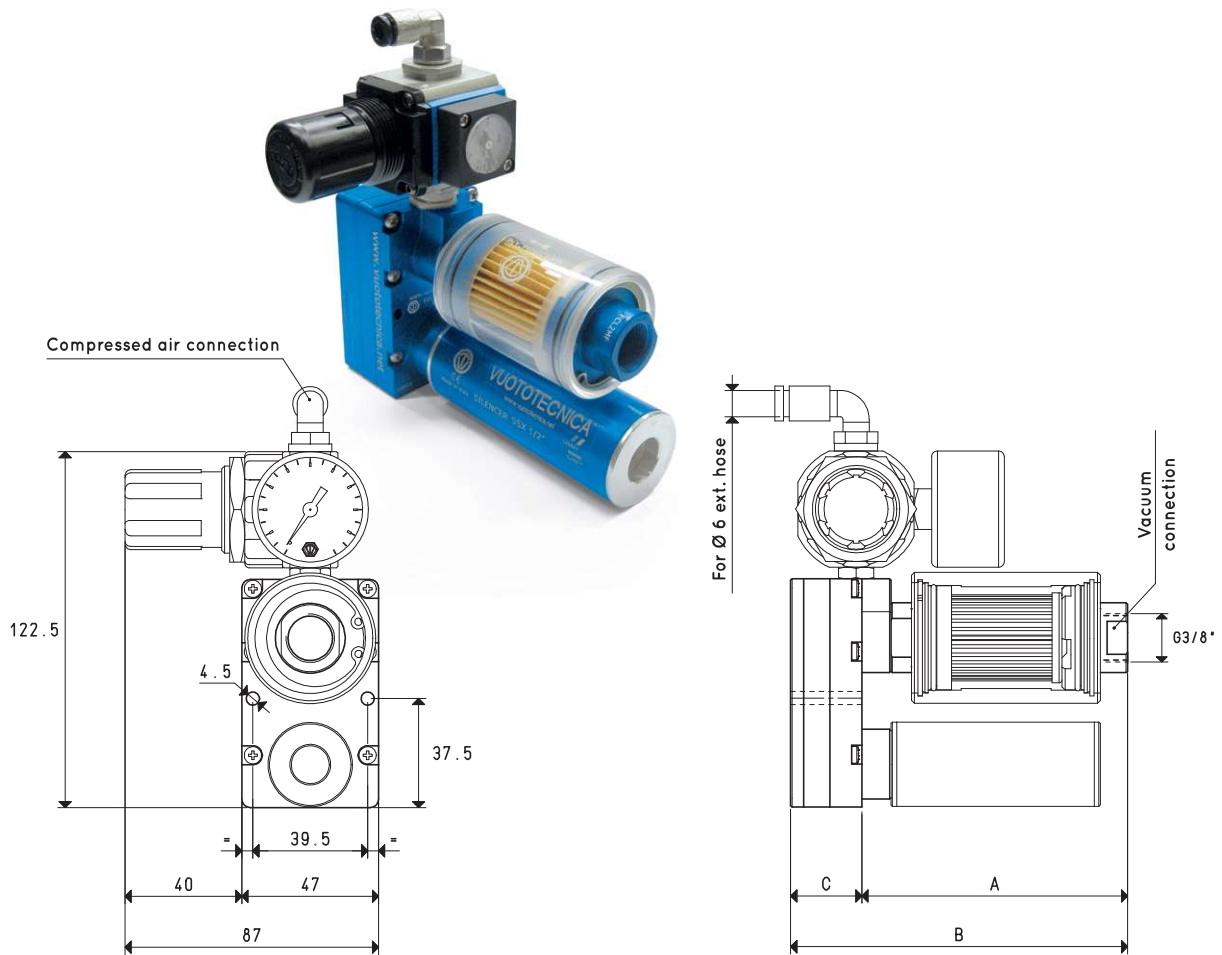

Item		PA 10				
Supply pressure	bar	1	2	3	4	5
Maximum level of vacuum	-KPa	20	42	62	80	85
Air consumption	NI/s	0.5	0.9	1.2	1.6	1.9
Intake air flow rate	m³/h	4.0	6.0	7.7	8.5	9.4
A				94		
B				118.5		
C				24.5		
Weight	Kg			0.59		
Item		PA 14				
Supply pressure	bar	1	2	3	4	5
Maximum level of vacuum	-KPa	20	42	62	80	85
Air consumption	NI/s	0.9	1.3	1.7	2.1	2.5
Intake air flow rate	m³/h	6.0	8.0	10.2	11.5	12.6
A				94		
B				118.5		
C				24.5		
Weight	Kg			0.60		
Item		PA 18				
Supply pressure	bar	1	2	3	4	5
Maximum level of vacuum	-KPa	20	42	62	80	85
Air consumption	NI/s	1.2	1.7	2.3	2.9	3.6
Intake air flow rate	m³/h	8.0	11.5	14.8	16.5	18.0
A				102		
B				136.5		
C				34.5		
Weight	Kg			0.62		
Operating temperature	°C	-20 / +80				

NOTE: All vacuum values indicated in the table are valid at the normal atmospheric pressure of 1013 mbar and obtained with a constant supply pressure.

Vacuum generator supply must be carried out with non-lubricated compressed air, 5 micron filtration, in accordance with standard ISO 8573-1 class 4.

Transformation ratio: N (newton) = Kg x 9.81 (force of gravity)

inch = $\frac{\text{mm}}{25.4}$; pounds = $\frac{\text{g}}{453.6} = \frac{\text{Kg}}{0.4536}$

Adapters for GAS - NPT threading available on page 1.130



PNEUMATIC SUCTION PUMPS PA

A newly designed range of ejectors has allowed creating this range of pneumatic suction pumps featuring an excellent ratio between the amount of consumed air and sucked air, as well as the ability to adjust the level of vacuum and flow rate according to the supply air pressure.

These pumps are powered with compressed air with a pressure ranging from 1 to 6 bar and they can produce a maximum vacuum of 90% and a suction flow rate between 15 and 320 m³/h, measured at a normal atmospheric pressure of 1013 mbar.

When designing these pumps, our attention was focused on noise. In fact, they are perfectly soundproofed and there are no moving parts subject to wear and vibrations. All this results in an extremely silent operation. Moreover, as they are based on the Venturi principle, they do not develop heat.

They are equipped as standard with a filter/pressure reducer unit for the supply air and a filter with microporous cartridge located on the suction inlet connection which can keep the finest dust and impurities. The excellent compressed air and sucked air filtration allows blowing air free from oil vapours, water condensation and impurities in the work environment, causing no pollution. The use of light alloys for making these pumps has allowed a considerable reduction of their weight thus allowing them to be directly installed onto the machine.

Thanks to their static operating principle, maintenance is reduced to a only a simple regular cleaning of the filters.



3D drawings are available on vuototecnica.net

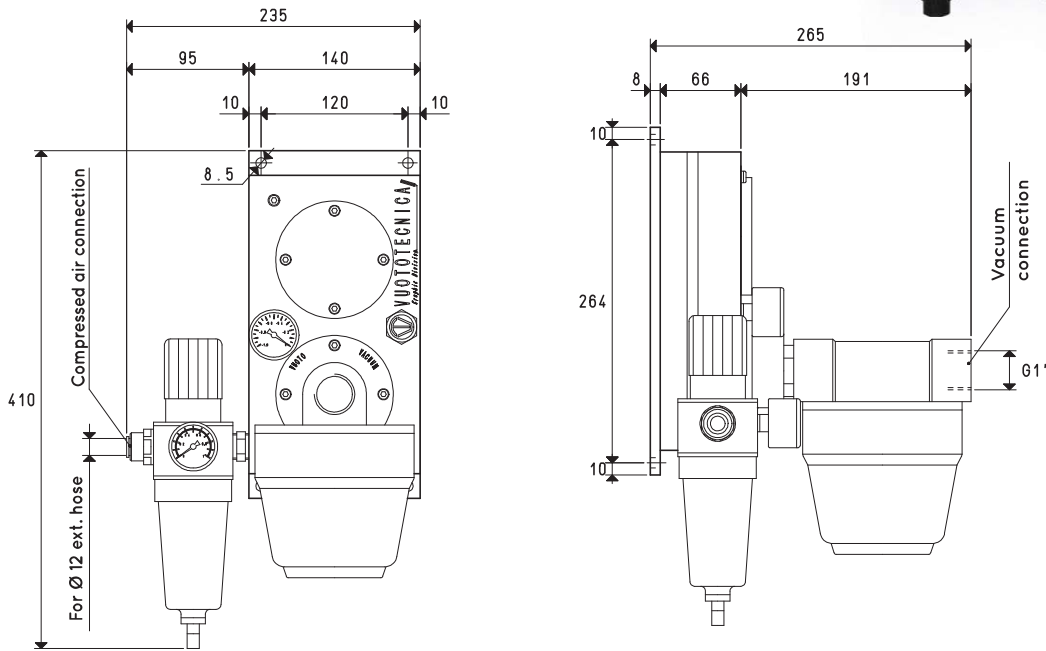

Item		PA40					
Supply pressure	bar	1	2	3	4	5	6
Maximum level of vacuum	-KPa	14	30	46	65	82	90
Air consumption	NI/s	1.0	1.5	2.0	2.3	2.7	3.2
Intake air flow rate	m ³ /h	15	23	30	36	39	42
Weight	Kg	6.2					
Item		PA70					
Supply pressure	bar	1	2	3	4	5	6
Maximum level of vacuum	-KPa	14	30	46	65	82	90
Air consumption	NI/s	2.0	3.0	4.1	4.9	5.7	6.6
Intake air flow rate	m ³ /h	29	47	58	65	73	80
Weight	Kg	6.2					
Item		PA100					
Supply pressure	bar	1	2	3	4	5	6
Maximum level of vacuum	-KPa	11	28	45	65	82	90
Air consumption	NI/s	3.0	4.6	6.2	7.2	8.5	9.8
Intake air flow rate	m ³ /h	28	57	75	88	98	108
Weight	Kg	6.2					
Operating temperature	°C	-20 / +80					

NOTE: All vacuum values indicated in the table are valid at the normal atmospheric pressure of 1013 mbar and obtained with a constant supply pressure.

Vacuum generator supply must be carried out with non-lubricated compressed air, 5 micron filtration, in accordance with standard ISO 8573-1 class 4.

Transformation ratio: N (newton) = Kg x 9.81 (force of gravity)

inch = $\frac{\text{mm}}{25.4}$; pounds = $\frac{\text{g}}{453.6} = \frac{\text{Kg}}{0.4536}$

Adapters for GAS - NPT threading available on page 1.130



PNEUMATIC SUCTION PUMPS PA 140, PA 170 and PA 200

3D drawings are available on vuotecnica.net

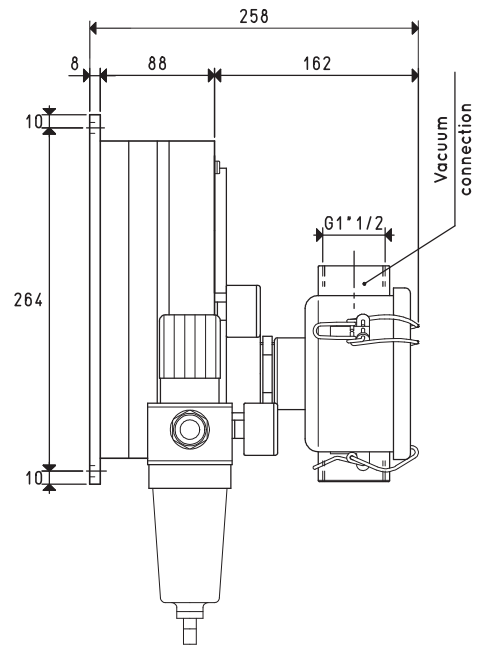
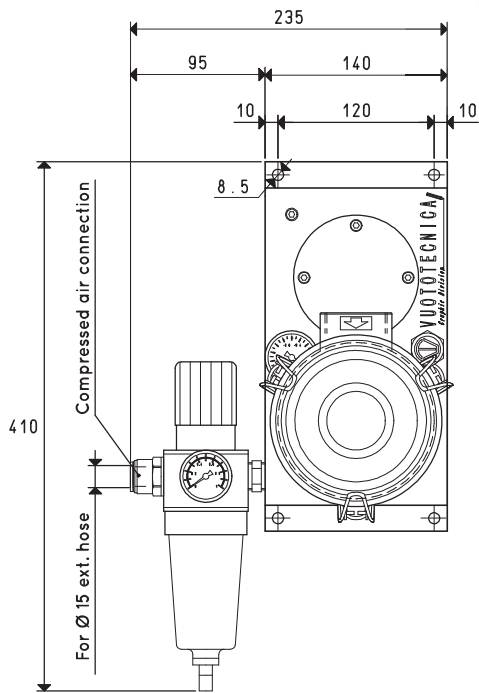

Item		PA 140					
Supply pressure	bar	1	2	3	4	5	6
Maximum level of vacuum	-KPa	15	35	55	70	85	90
Air consumption	Nl/s	4.1	6.2	8.3	9.6	11.4	13.0
Intake air flow rate	m ³ /h	45	80	106	125	140	152
Weight	Kg	7.2					
Item		PA 170					
Supply pressure	bar	1	2	3	4	5	6
Maximum level of vacuum	-KPa	15	35	55	70	85	90
Air consumption	Nl/s	5.1	7.7	10.3	12.1	14.2	16.3
Intake air flow rate	m ³ /h	53	98	128	150	168	182
Weight	Kg	7.2					
Item		PA 200					
Supply pressure	bar	1	2	3	4	5	6
Maximum level of vacuum	-KPa	15	35	55	70	85	90
Air consumption	Nl/s	6.0	9.1	12.2	14.2	16.9	19.4
Intake air flow rate	m ³ /h	60	110	142	170	188	200
Weight	Kg	7.2					
Operating temperature	°C	-20 / +80					

NOTE: All vacuum values indicated in the table are valid at the normal atmospheric pressure of 1013 mbar and obtained with a constant supply pressure.

Vacuum generator supply must be carried out with non-lubricated compressed air, 5 micron filtration, in accordance with standard ISO 8573-1 class 4.

Transformation ratio: N (newton) = Kg x 9.81 (force of gravity)

inch = $\frac{\text{mm}}{25.4}$; pounds = $\frac{\text{g}}{453.6} = \frac{\text{Kg}}{0.4536}$

Adapters for GAS - NPT threading available on page 1.130

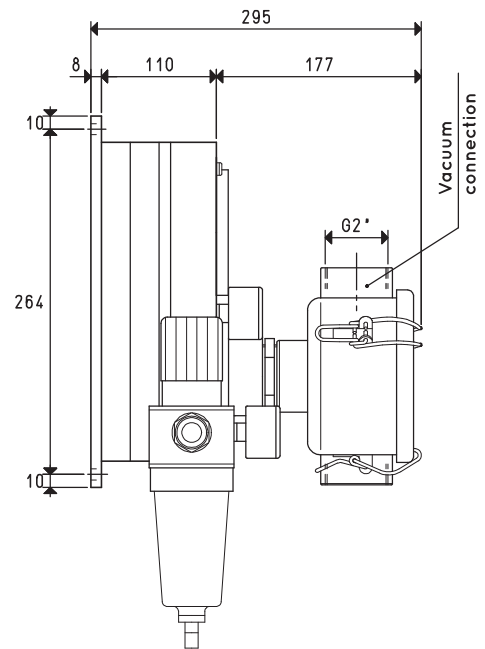
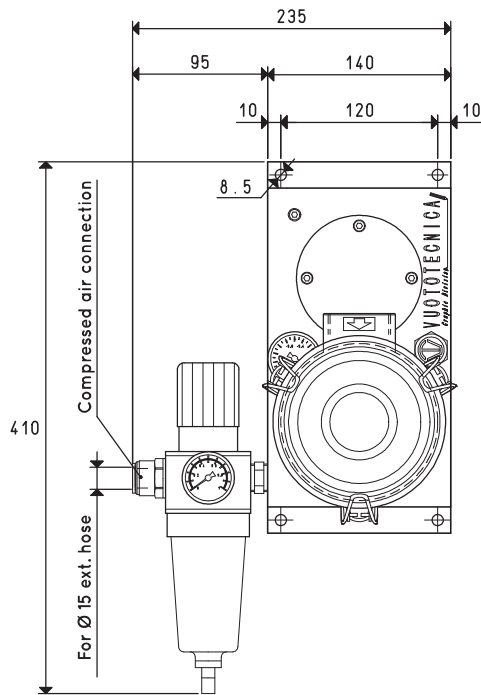

Item		PA250					
Supply pressure	bar	1	2	3	4	5	6
Maximum level of vacuum	-KPa	15	35	55	70	85	90
Air consumption	NI/s	7.5	11.2	15.0	17.3	20.7	24.0
Intake air flow rate	m ³ /h	100	145	190	224	252	280
Weight	Kg	8,1					
Item		PA300					
Supply pressure	bar	1	2	3	4	5	6
Maximum level of vacuum	-KPa	15	35	55	70	85	90
Air consumption	NI/s	9.0	13.5	18.1	20.4	24.8	29.0
Intake air flow rate	m ³ /h	106	160	213	240	290	320
Weight	Kg	8.1					
Operating temperature	°C	-20 / +80					

NOTE: All vacuum values indicated in the table are valid at the normal atmospheric pressure of 1013 mbar and obtained with a constant supply pressure.

Vacuum generator supply must be carried out with non-lubricated compressed air, 5 micron filtration, in accordance with standard ISO 8573-1 class 4.

Transformation ratio: N (newton) = Kg x 9.81 (force of gravity)

inch = $\frac{mm}{25.4}$; pounds = $\frac{g}{453.6} = \frac{Kg}{0.4536}$

Adapters for GAS - NPT threading available on page 1.130



SMALL PNEUMATIC BLOWING PUMPS PS

The assembly of a pressure adjuster equipped with pressure gauge and of an FCL filter on the suction inlet connection of a vacuum generator of the M...SSX range has allowed creating these small pneumatic suction pumps. Their main features include reduced overall dimensions compared to their technical performance.

The pressure and flow rate can be adjusted according to the supply air pressure. These pumps are powered with compressed air with a pressure ranging from 1 to 5 bar and can produce a maximum pressure of 0.7 bar and a blowing flow rate between 2.7 and 31 m³/h, measured at a normal atmospheric pressure of 1013 mbar.

Based on the Venturi principle, they do not develop heat.

The filter equipped with microporous cartridge located on the air inlet connection can keep the finest dust and impurities.

Thanks to their static operating principle, maintenance is reduced to only a simple regular cleaning of the filter.

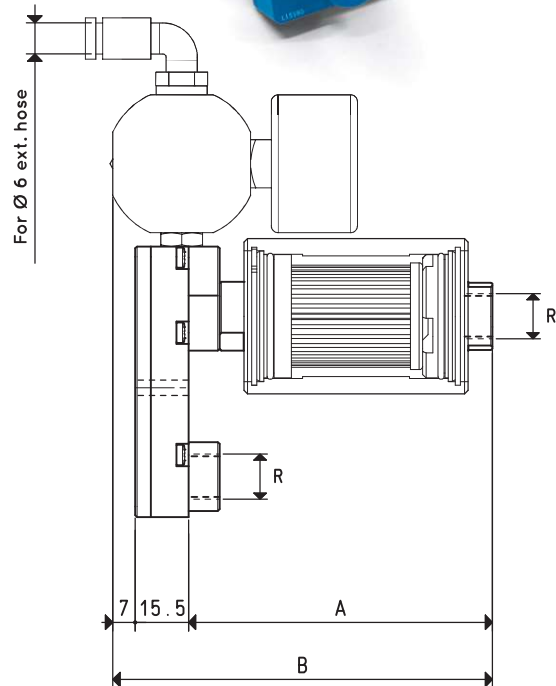
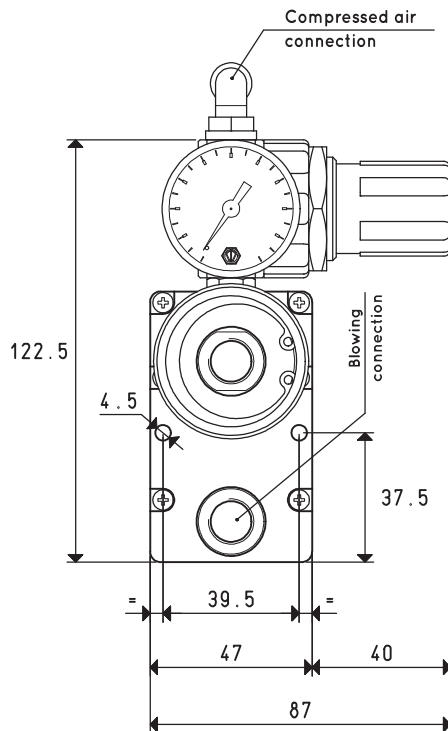

Item	PS 3					
Supply pressure	bar	1	2	3	4	5
Maximum blowing pressure	bar	0.1	0.2	0.3	0.5	0.7
Air consumption	Nl/s	0.2	0.4	0.5	0.7	0.8
Blown air flow rate	m ³ /h	2.7	3.9	4.8	5.9	6.5
A		88				
B		110.5				
R	Ø	G1/4"				
Weight	Kg	0.44				
Item	PS 7					
Supply pressure	bar	1	2	3	4	5
Maximum blowing pressure	bar	0.1	0.2	0.3	0.5	0.7
Air consumption	Nl/s	0.4	0.6	0.8	1.2	1.4
Blown air flow rate	m ³ /h	4.4	6.1	8.2	10.1	11.2
A		89				
B		111.5				
R		G3/8"				
Weight	Kg	0.45				
Operating temperature	°C	-20 / +80				

NOTE: All vacuum values indicated in the table are valid at the normal atmospheric pressure of 1013 mbar and obtained with a constant supply pressure.

Vacuum generator supply must be carried out with non-lubricated compressed air, 5 micron filtration, in accordance with standard ISO 8573-1 class 4.

Transformation ratio: N (newton) = Kg x 9.81 (force of gravity)

inch = $\frac{\text{mm}}{25.4}$; pounds = $\frac{\text{g}}{453.6} = \frac{\text{Kg}}{0.4536}$

Adapters for GAS - NPT threading available on page 1.130

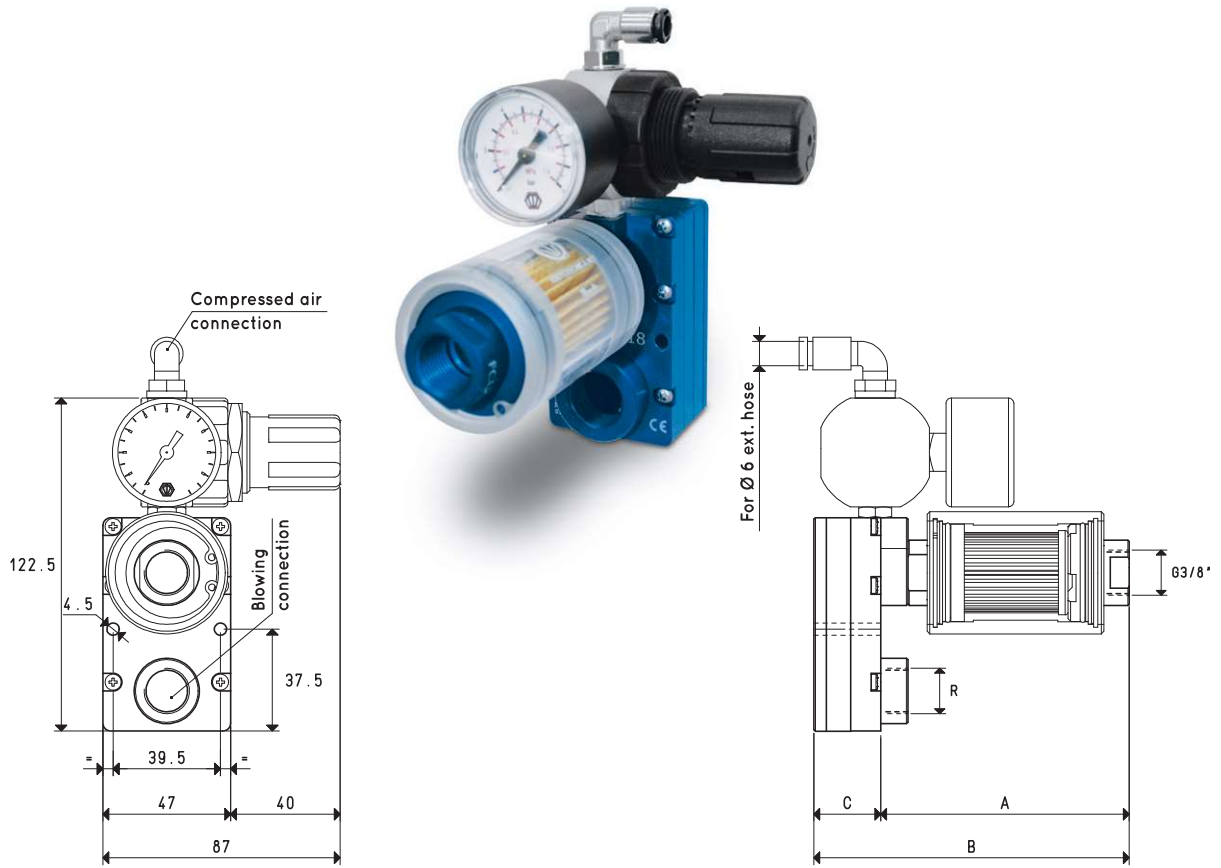

Item		PS 10				
Supply pressure	bar	1	2	3	4	5
Maximum blowing pressure	-KPa	0.1	0.2	0.3	0.5	0.7
Air consumption	Nl/s	0.5	0.9	1.2	1.6	1.9
Blown air flow rate	m³/h	5.8	9.2	12.0	14.2	16.2
A				94		
B				118.5		
C				24.5		
R				G3/8"		
Weight	Kg			0.49		
Item		PS 14				
Supply pressure	bar	1	2	3	4	5
Maximum blowing pressure	-KPa	0.1	0.2	0.3	0.5	0.7
Air consumption	Nl/s	0.9	1.3	1.7	2.1	2.5
Blown air flow rate	m³/h	9.2	12.6	16.3	19.0	21.6
A				94		
B				118.5		
C				24.5		
R				G3/8"		
Weight	Kg			0.50		
Item		PS 18				
Supply pressure	bar	1	2	3	4	5
Maximum blowing pressure	-KPa	0.1	0.2	0.3	0.5	0.7
Air consumption	Nl/s	1.2	1.7	2.3	2.9	3.6
Blown air flow rate	m³/h	12.3	17.6	23.0	26.9	31.0
A				94		
B				128.5		
C				34.5		
R				G1/2"		
Weight	Kg			0.52		
Operating temperature	°C	-20 / +80				

NOTE: All vacuum values indicated in the table are valid at the normal atmospheric pressure of 1013 mbar and obtained with a constant supply pressure.

Vacuum generator supply must be carried out with non-lubricated compressed air, 5 micron filtration, in accordance with standard ISO 8573-1 class 4.



PNEUMATIC BLOWING PUMPS PS

3D drawings are available on vuototecnica.net

A newly designed range of ejectors has allowed creating this range of pneumatic blowing pumps featuring an excellent ratio between the amount of consumed air and generated air, as well as the ability to adjust the pressure and flow rate according to the supply air pressure. These pumps are powered with compressed air with a pressure ranging from 1 to 6 bar and have a blowing flow rate between 18 and 425 m³/h, measured at a normal atmospheric pressure of 1013 mbar.

When designing these pumps, our attention was focused on noise. In fact, they are perfectly soundproofed and there are no moving parts subject to wear and vibrations. All this results in an extremely silent operation.

Moreover, as they are based on the Venturi principle, they do not develop heat.

They are equipped as standard with a filter/pressure reducer unit for the supply air and a filter with microporous cartridge located on the air inlet connection which can keep the finest dust and impurities.

The excellent filtration of the compressed air supply and intake air allows the intake of air free from oil, water condensates or impurities from between the sheets of paper to be separated in the working environment, with no pollution.

The use of light alloys for making these pumps has allowed a considerable reduction of their weight thus allowing them to be directly installed onto the machine.

Thanks to their static operating principle, maintenance is reduced to a only a simple regular cleaning of the filters.

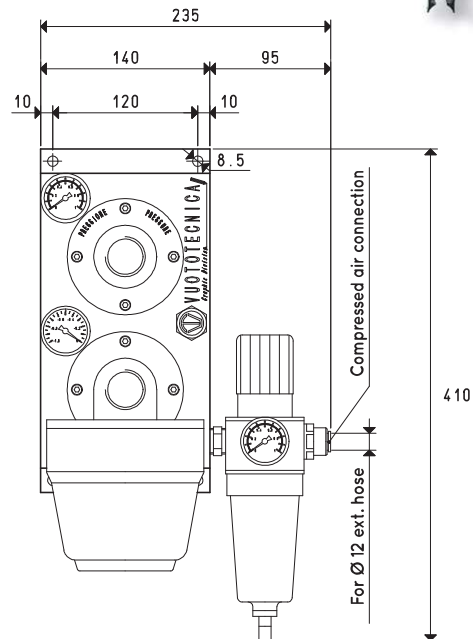
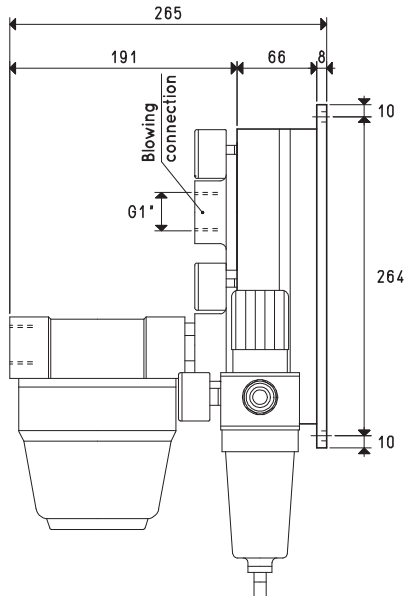

Item		PS 40					
Supply pressure	bar	1	2	3	4	5	6
Maximum blowing pressure	bar	0.1	0.2	0.3	0.5	0.7	0.8
Air consumption	NI/s	1.0	1.5	2.0	2.3	2.7	3.2
Blown air flow rate	m ³ /h	18	28	37	44	48	53
Weight	Kg	6.3					
Item		PS 70					
Supply pressure	bar	1	2	3	4	5	6
Maximum blowing pressure	bar	0.1	0.2	0.3	0.5	0.7	0.8
Air consumption	NI/s	2.0	3.0	4.1	4.9	5.7	6.6
Blown air flow rate	m ³ /h	36	57	72	83	93	104
Weight	Kg	6.3					
Item		PS 100					
Supply pressure	bar	1	2	3	4	5	6
Maximum blowing pressure	bar	0.1	0.2	0.3	0.5	0.7	0.8
Air consumption	NI/s	3.0	4.6	6.2	7.2	8.5	9.8
Blown air flow rate	m ³ /h	38	73	97	114	129	144
Weight	Kg	6.3					
Operating temperature	°C	-20 / +80					

NOTE: All vacuum values indicated in the table are valid at the normal atmospheric pressure of 1013 mbar and obtained with a constant supply pressure.

Vacuum generator supply must be carried out with non-lubricated compressed air, 5 micron filtration, in accordance with standard ISO 8573-1 class 4.

Transformation ratio: N (newton) = Kg x 9.81 (force of gravity)

inch = $\frac{\text{mm}}{25.4}$; pounds = $\frac{\text{g}}{453.6} = \frac{\text{Kg}}{0.4536}$

Adapters for GAS - NPT threading available on page 1.130

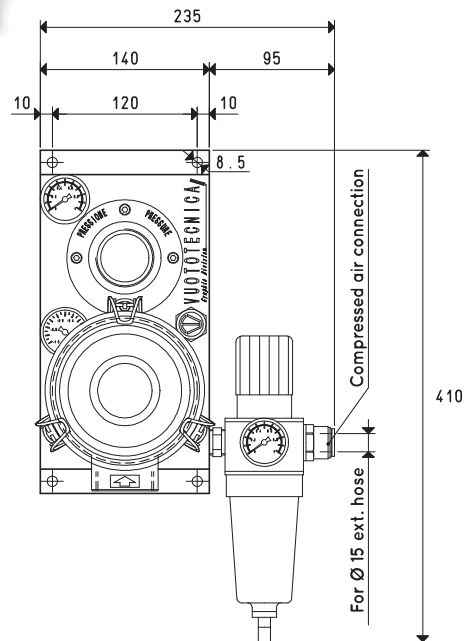
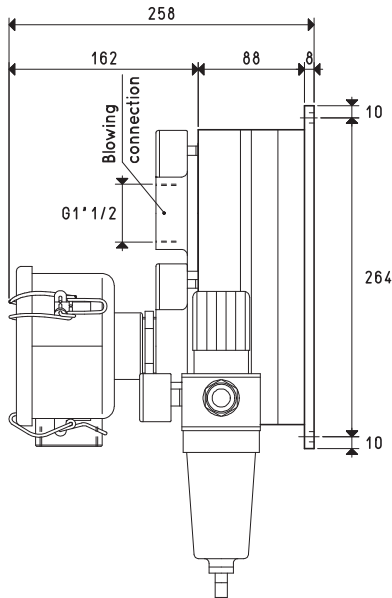

Item		PS 140					
Supply pressure	bar	1	2	3	4	5	6
Maximum blowing pressure	bar	0.1	0.2	0.3	0.5	0.7	0.8
Air consumption	NI/s	4.1	6.2	8.3	9.6	11.4	13.0
Blown air flow rate	m ³ /h	59	102	135	160	181	199
Weight	Kg	7.3					
Item		PS 170					
Supply pressure	bar	1	2	3	4	5	6
Maximum blowing pressure	bar	0.1	0.2	0.3	0.5	0.7	0.8
Air consumption	NI/s	5.1	7.7	10.3	12.1	14.2	16.3
Blown air flow rate	m ³ /h	71	125	165	194	219	240
Weight	Kg	7.3					
Item		PS 200					
Supply pressure	bar	1	2	3	4	5	6
Maximum blowing pressure	bar	0.1	0.2	0.3	0.5	0.7	0.8
Air consumption	NI/s	6.0	9.1	12.2	14.2	16.9	19.4
Blown air flow rate	m ³ /h	81	142	185	221	249	270
Weight	Kg	7.3					
Operating temperature	°C	-20 / +80					

NOTE: All vacuum values indicated in the table are valid at the normal atmospheric pressure of 1013 mbar and obtained with a constant supply pressure.

Vacuum generator supply must be carried out with non-lubricated compressed air, 5 micron filtration, in accordance with standard ISO 8573-1 class 4.

Transformation ratio: N (newton) = Kg x 9.81 (force of gravity)

inch = $\frac{\text{mm}}{25.4}$; pounds = $\frac{\text{g}}{453.6} = \frac{\text{Kg}}{0.4536}$

Adapters for GAS - NPT threading available on page 1.130



PNEUMATIC BLOWING PUMPS PS 250 and PS 300

3D drawings are available on vuototecnica.net

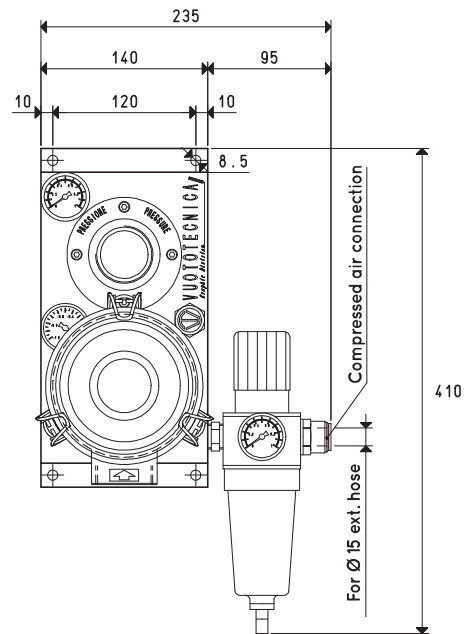
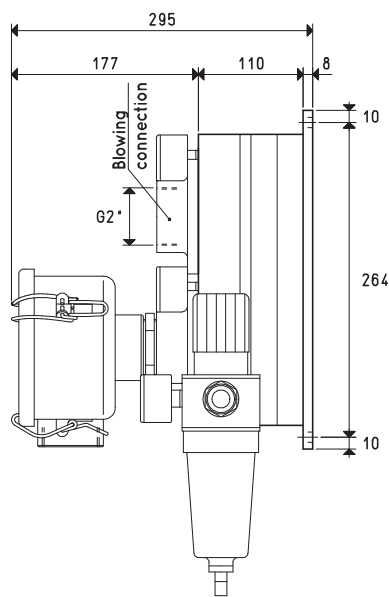

Item		PS 250					
Supply pressure	bar	1	2	3	4	5	6
Maximum blowing pressure	bar	0.1	0.2	0.3	0.5	0.7	0.8
Air consumption	NI/s	7.5	11.2	15.0	17.3	20.7	24.0
Blown air flow rate	m ³ /h	127	185	244	286	327	366
Weight	Kg	8.2					
Item		PS 300					
Supply pressure	bar	1	2	3	4	5	6
Maximum blowing pressure	bar	0.1	0.2	0.3	0.5	0.7	0.8
Air consumption	NI/s	9.0	13.5	18.1	20.4	24.8	29.0
Blown air flow rate	m ³ /h	138	208	278	313	379	424
Weight	Kg	8.2					
Operating temperature	°C	-20 / +80					

NOTE: All vacuum values indicated in the table are valid at the normal atmospheric pressure of 1013 mbar and obtained with a constant supply pressure.

Vacuum generator supply must be carried out with non-lubricated compressed air, 5 micron filtration, in accordance with standard ISO 8573-1 class 4.

Transformation ratio: N (newton) = Kg x 9.81 (force of gravity)

inch = $\frac{\text{mm}}{25.4}$; pounds = $\frac{\text{g}}{453.6} = \frac{\text{Kg}}{0.4536}$

Adapters for GAS - NPT threading available on page 1.130



SMALL COMBINED PNEUMATIC SUCTION PUMPS PA AND BLOWING PUMPS PS PA 3 ÷ 7 WITH PS 3 ÷ 7

All the small pneumatic suction and blowing pumps previously described can be combined regardless of their suction or blowing flow rate.

Given the enormous number of possible combinations, for space reasons, this catalogue only describes combinations of pumps with the same size.

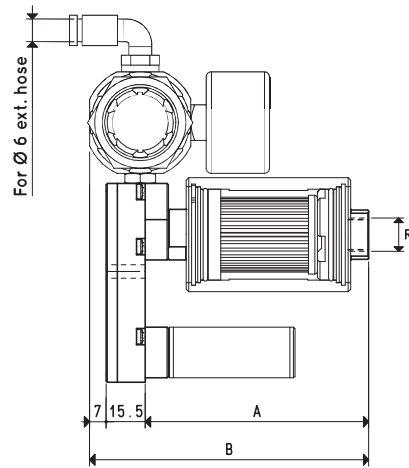
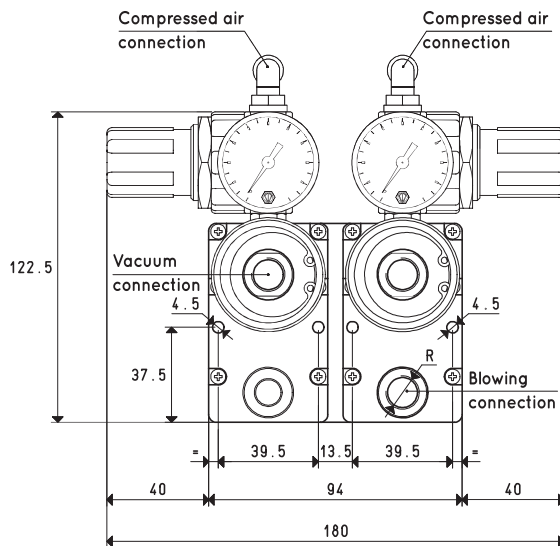

Item		PA 3				
Supply pressure	bar	1	2	3	4	5
Maximum level of vacuum	-KPa	20	42	62	80	85
Air consumption	NI/s	0.2	0.4	0.5	0.7	0.8
Intake air flow rate	m ³ /h	2.0	2.5	3.0	3.4	3.6
A		88				
B		110.5				
R	∅	G1/4"				
Weight	Kg	0.45				

Item		PS 3				
Supply pressure	bar	1	2	3	4	5
Maximum blowing pressure	bar	0.1	0.2	0.3	0.5	0.7
Air consumption	NI/s	0.2	0.4	0.5	0.7	0.8
Blown air flow rate	m ³ /h	2.7	3.9	4.8	5.9	6.5
A		88				
B		110.5				
R	∅	G1/4"				
Weight	Kg	0.44				

Item		PA 7				
Supply pressure	bar	1	2	3	4	5
Maximum level of vacuum	-KPa	20	42	62	80	85
Air consumption	NI/s	0.4	0.6	0.8	1.2	1.4
Intake air flow rate	m ³ /h	3.0	4.0	5.4	5.8	6.2
A		88				
B		110.5				
R	∅	G3/8"				
Weight	Kg	0.46				

Item		PS 7				
Supply pressure	bar	1	2	3	4	5
Maximum blowing pressure	bar	0.1	0.2	0.3	0.5	0.7
Air consumption	NI/s	0.4	0.6	0.8	1.2	1.4
Blown air flow rate	m ³ /h	4.4	6.1	8.2	10.1	11.2
A		88				
B		110.5				
R	∅	G3/8"				
Weight	Kg	0.45				

Item		Operating temperature				
Operating temperature	°C	-20 / +80				

Item		Operating temperature				
Operating temperature	°C	-20 / +80				

NOTE: All vacuum values indicated in the table are valid at the normal atmospheric pressure of 1013 mbar and obtained with a constant supply pressure.

Vacuum generator supply must be carried out with non-lubricated compressed air, 5 micron filtration, in accordance with standard ISO 8573-1 class 4.



SMALL COMBINED PNEUMATIC SUCTION PUMPS PA AND BLOWING PUMPS PS PA 10 ÷ 18 WITH PS 10 ÷ 18

3D drawings are available on vuotecnica.net

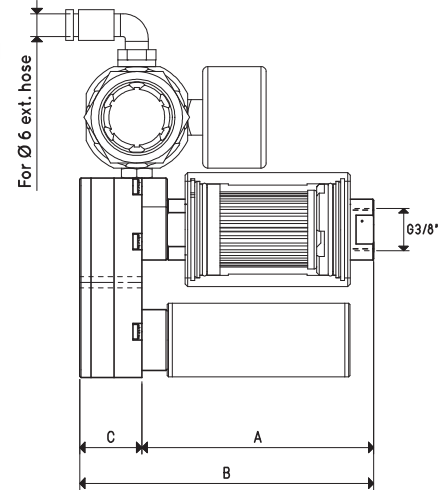
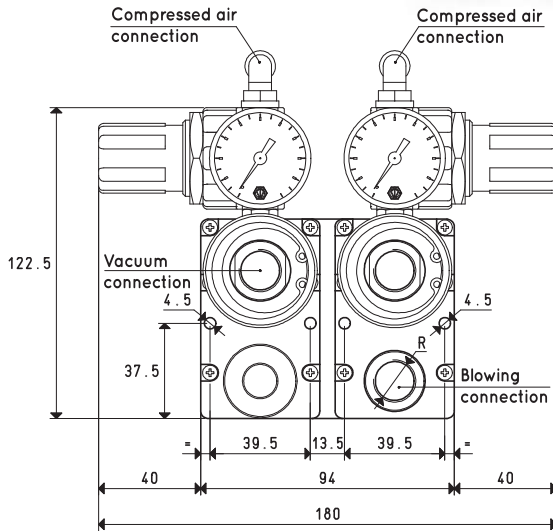

Item		PA 10				
Supply pressure	bar	1	2	3	4	5
Maximum level of vacuum	-KPa	20	42	62	80	85
Air consumption	NI/s	0.5	0.9	1.2	1.6	1.9
Intake air flow rate	m³/h	4.0	6.0	7.7	8.5	9.4
A		94				
B		118.5				
C		24.5				
Weight	Kg	0.59				

Item		PA 14				
Supply pressure	bar	1	2	3	4	5
Maximum level of vacuum	-KPa	20	42	62	80	85
Air consumption	NI/s	0.9	1.3	1.7	2.1	2.5
Intake air flow rate	m³/h	6.0	8.0	10.2	11.5	12.6
A		94				
B		118.5				
C		24.5				
Weight	Kg	0.60				

Item		PA 18				
Supply pressure	bar	1	2	3	4	5
Maximum level of vacuum	-KPa	20	42	62	80	85
Air consumption	NI/s	1.2	1.7	2.3	2.9	3.6
Intake air flow rate	m³/h	8.0	11.5	14.8	16.5	18.0
A		94				
B		136.5				
C		34.5				
Weight	Kg	0.62				
Operating temperature	°C	-20 / +80				

Item		PS 10				
Supply pressure	bar	1	2	3	4	5
Maximum blowing pressure	bar	0.1	0.2	0.3	0.5	0.7
Air consumption	NI/s	0.5	0.9	1.2	1.6	1.9
Blown air flow rate	m³/h	5.8	9.2	12.0	14.2	16.2
A		94				
B		118.5				
C		24.5				
R	Ø	G3/8"				
Weight	Kg	0.49				

Item		PS 14				
Supply pressure	bar	1	2	3	4	5
Maximum blowing pressure	bar	0.1	0.2	0.3	0.5	0.7
Air consumption	NI/s	0.9	1.3	1.7	2.1	2.5
Blown air flow rate	m³/h	9.2	12.6	16.3	19.0	21.6
A		94				
B		118.5				
C		24.5				
R	Ø	G3/8"				
Weight	Kg	0.50				

Item		PS 18				
Supply pressure	bar	1	2	3	4	5
Maximum blowing pressure	bar	0.1	0.2	0.3	0.5	0.7
Air consumption	NI/s	1.2	1.7	2.3	2.9	3.6
Blown air flow rate	m³/h	12.3	17.6	23.0	26.9	31.0
A		94				
B		128.5				
C		34.5				
R	Ø	G1/2"				
Weight	Kg	0.52				
Operating temperature	°C	-20 / +80				

NOTE: All vacuum values indicated in the table are valid at the normal atmospheric pressure of 1013 mbar and obtained with a constant supply pressure.

Vacuum generator supply must be carried out with non-lubricated compressed air, 5 micron filtration, in accordance with standard ISO 8573-1 class 4.

Transformation ratio: N (newton) = Kg x 9.81 (force of gravity)

inch = $\frac{mm}{25.4}$; pounds = $\frac{g}{453.6} = \frac{Kg}{0.4536}$

Adapters for GAS - NPT threading available on page 1.130



COMBINED PNEUMATIC SUCTION PUMPS PA AND BLOWING PUMPS PS PA 40 ÷ 100 WITH PS 40 ÷ 100

All the pneumatic suction and blowing pumps previously described can be combined regardless of their suction or blowing flow rate. Given the enormous number of possible combinations, for space reasons, this catalogue only describes combinations of pumps with the same size.

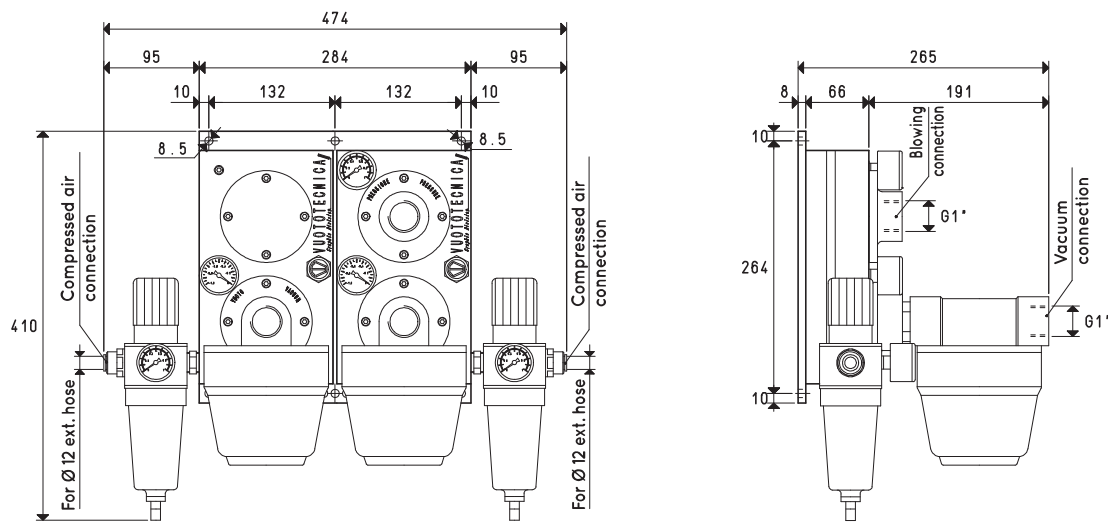

Item		PA 40					
Supply pressure	bar	1	2	3	4	5	6
Maximum level of vacuum	-KPa	14	30	46	65	82	90
Air consumption	NI/s	1.0	1.5	2.0	2.3	2.7	3.2
Intake air flow rate	m ³ /h	15	23	30	36	39	42
Weight	Kg	6.2					
Item		PA 70					
Supply pressure	bar	1	2	3	4	5	6
Maximum level of vacuum	-KPa	14	30	46	65	82	90
Air consumption	NI/s	2.0	3.0	4.1	4.9	5.7	6.6
Intake air flow rate	m ³ /h	29	47	58	65	73	80
Weight	Kg	6.2					
Item		PA 100					
Supply pressure	bar	1	2	3	4	5	6
Maximum level of vacuum	-KPa	14	30	46	65	82	90
Air consumption	NI/s	3.0	4.6	6.2	7.2	8.5	9.8
Intake air flow rate	m ³ /h	28	57	75	88	98	108
Weight	Kg	6.2					
Operating temperature	°C	-20 / +80					

Item		PS 40					
Supply pressure	bar	1	2	3	4	5	6
Maximum blowing pressure	-KPa	0.1	0.2	0.3	0.5	0.7	0.8
Air consumption	NI/s	1.0	1.5	2.0	2.3	2.7	3.2
Blown air flow rate	m ³ /h	18	28	37	44	48	53
Weight	Kg	6.3					
Item		PS 70					
Supply pressure	bar	1	2	3	4	5	6
Maximum blowing pressure	-KPa	0.1	0.2	0.3	0.5	0.7	0.8
Air consumption	NI/s	2.0	3.0	4.1	4.9	5.7	6.6
Blown air flow rate	m ³ /h	36	57	72	83	93	104
Weight	Kg	6.3					
Item		PS 100					
Supply pressure	bar	1	2	3	4	5	6
Maximum blowing pressure	-KPa	0.1	0.2	0.3	0.5	0.7	0.8
Air consumption	NI/s	3.0	4.6	6.2	7.2	8.5	9.8
Blown air flow rate	m ³ /h	38	73	97	114	129	144
Weight	Kg	6.3					
Operating temperature	°C	-20 / +80					

NOTE: All vacuum values indicated in the table are valid at the normal atmospheric pressure of 1013 mbar and obtained with a constant supply pressure.

Vacuum generator supply must be carried out with non-lubricated compressed air, 5 micron filtration, in accordance with standard ISO 8573-1 class 4.

Transformation ratio: N (newton) = Kg x 9.81 (force of gravity)

inch = $\frac{\text{mm}}{25.4}$; pounds = $\frac{\text{g}}{453.6} = \frac{\text{Kg}}{0.4536}$

Adapters for GAS - NPT threading available on page 1.130



COMBINED PNEUMATIC SUCTION PUMPS PA AND BLOWING PUMPS PS PA 140 ÷ 200 WITH PS 140 ÷ 200

3D drawings are available on vuotecnica.net

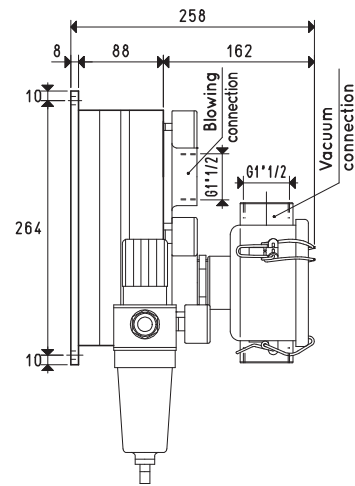
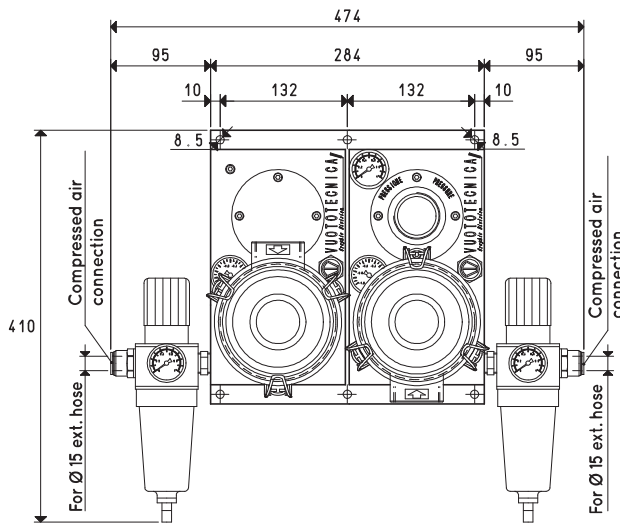

Item		PA 140					
Supply pressure	bar	1	2	3	4	5	6
Maximum level of vacuum	-KPa	15	35	55	70	85	90
Air consumption	NI/s	4.1	6.2	8.3	9.6	11.4	13.0
Intake air flow rate	m ³ /h	45	80	106	125	140	152
Weight	Kg	7.2					
Item		PA 170					
Supply pressure	bar	1	2	3	4	5	6
Maximum level of vacuum	-KPa	15	35	55	70	85	90
Air consumption	NI/s	5.1	7.7	10.3	12.1	14.2	16.3
Intake air flow rate	m ³ /h	53	98	128	150	168	182
Weight	Kg	7.2					
Item		PA 200					
Supply pressure	bar	1	2	3	4	5	6
Maximum level of vacuum	-KPa	15	35	55	70	85	90
Air consumption	NI/s	6.0	9.1	12.2	14.2	16.9	19.4
Intake air flow rate	m ³ /h	60	110	142	170	188	200
Weight	Kg	7.2					
Operating temperature	°C	-20 / +80					

Item		PS 140					
Supply pressure	bar	1	2	3	4	5	6
Maximum blowing pressure	-KPa	0.1	0.2	0.3	0.5	0.7	0.8
Air consumption	NI/s	4.1	6.2	8.3	9.6	11.4	13.0
Blown air flow rate	m ³ /h	59	102	135	160	181	199
Weight	Kg	7.3					
Item		PS 170					
Supply pressure	bar	1	2	3	4	5	6
Maximum blowing pressure	-KPa	0.1	0.2	0.3	0.5	0.7	0.8
Air consumption	NI/s	5.1	7.7	10.3	12.1	14.2	16.3
Blown air flow rate	m ³ /h	71	125	165	194	219	240
Weight	Kg	7.3					
Item		PS 200					
Supply pressure	bar	1	2	3	4	5	6
Maximum blowing pressure	-KPa	0.1	0.2	0.3	0.5	0.7	0.8
Air consumption	NI/s	6.0	9.1	12.2	14.2	16.9	19.4
Blown air flow rate	m ³ /h	81	142	185	221	249	270
Weight	Kg	7.3					
Operating temperature	°C	-20 / +80					

NOTE: All vacuum values indicated in the table are valid at the normal atmospheric pressure of 1013 mbar and obtained with a constant supply pressure.

Vacuum generator supply must be carried out with non-lubricated compressed air, 5 micron filtration, in accordance with standard ISO 8573-1 class 4.

Transformation ratio: N (newton) = Kg x 9.81 (force of gravity)

inch = $\frac{mm}{25.4}$; pounds = $\frac{g}{453.6} = \frac{Kg}{0.4536}$

Adapters for GAS - NPT threading available on page 1.130

COMBINED PNEUMATIC SUCTION PUMPS PA AND BLOWING PUMPS PS PA 250 ÷ 300 WITH PS 250 ÷ 300



3D drawings are available on vuototecnica.net

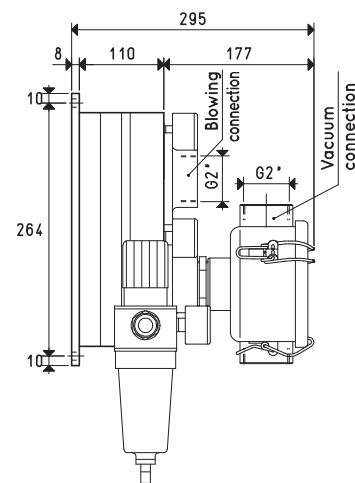
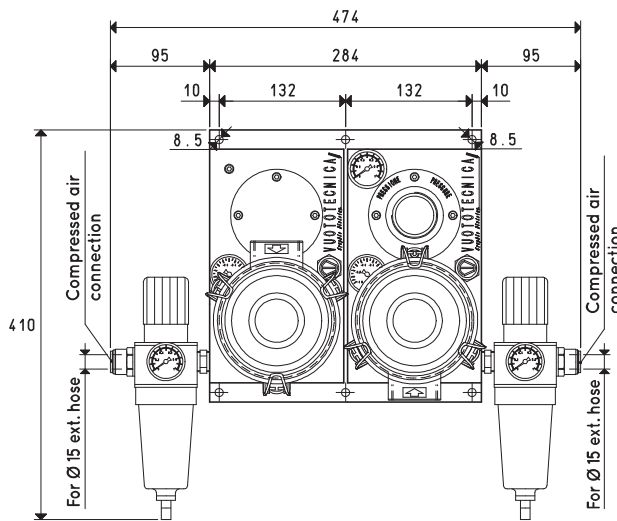

Item		PA 250					
Supply pressure	bar	1	2	3	4	5	6
Maximum level of vacuum	-KPa	15	35	55	70	85	90
Air consumption	NI/s	7.5	11.2	15.0	17.3	20.7	24.0
Intake air flow rate	m ³ /h	100	145	190	224	252	280
Weight	Kg	8.1					

Item		PA 300					
Supply pressure	bar	1	2	3	4	5	6
Maximum level of vacuum	-KPa	15	35	55	70	85	90
Air consumption	NI/s	9.0	13.5	18.1	20.4	24.8	29.0
Intake air flow rate	m ³ /h	106	160	213	240	290	320
Weight	Kg	8.1					
Operating temperature	°C	-20 / +80					

Item		PS 250					
Supply pressure	bar	1	2	3	4	5	6
Maximum blowing pressure	-KPa	0.1	0.2	0.3	0.5	0.7	0.8
Air consumption	NI/s	7.5	11.2	15.0	17.3	20.7	24.0
Blown air flow rate	m ³ /h	127	185	244	286	327	366
Weight	Kg	8.2					

Item		PS 300					
Supply pressure	bar	1	2	3	4	5	6
Maximum blowing pressure	-KPa	0.1	0.2	0.3	0.5	0.7	0.8
Air consumption	NI/s	9.0	13.5	18.1	20.4	24.8	29.0
Blown air flow rate	m ³ /h	138	208	278	313	379	424
Weight	Kg	8.2					
Operating temperature	°C	-20 / +80					

NOTE: All vacuum values indicated in the table are valid at the normal atmospheric pressure of 1013 mbar and obtained with a constant supply pressure.

Vacuum generator supply must be carried out with non-lubricated compressed air, 5 micron filtration, in accordance with standard ISO 8573-1 class 4.

Transformation ratio: N (newton) = Kg x 9.81 (force of gravity)

inch = $\frac{\text{mm}}{25.4}$; pounds = $\frac{\text{g}}{453.6} = \frac{\text{Kg}}{0.4536}$

Adapters for GAS - NPT threading available on page 1.130



SUCTION AND BLOWING SYSTEM AS

With the suction and blowing system AS, we have tried to provide the printing industry with an answer to most of their requirements regarding the management of paper during the printing process, or rather:

- The concentration of all the necessary pumps and commands on one single piece.
- An increased printing quality thanks to individually controlled pumps.
- An increase of productivity resulting from the configuration and use of individual pumps.
- Reduced machine idle state due to the pneumatic pumps based on the Venturi principle.
- An improvement of the work environment thanks to the noise reduction, absence of heat and the emission of air free of oil vapours, water condensation and impurities between the sheets of paper to be separated and in the work environment.
- Energy saving due to a low compressed air consumption compared to the amount of sucked (or generated) air.
- Maintenance reduced to a regular cleaning of the filters.

The suction and blowing system AS is composed of a metal, easy-to-place cabinet, inside of which the combined pneumatic pumps PA and PS are located with the supply compressed air interception and adjustment valves.

The suction and blowing capacities of the pumps are determined according to the client's requirements or to technical specifications of the machine manufacturer.

The blowing and suction connectors are located on the sides of the cabinet for the connection to the application, as well as the filters equipped with micro-porous cartridge against fine dust.

The following are installed on the control panel:

- The pneumatic main switch for supply compressed air interception with a pressure gauge for a direct reading of the line pressure.
- The pneumatic switches for supply compressed air interception of every single pump.
- The pressure reducers with relative pressure gauges for adjusting the compressed air of every single pump. The vacuum (or pressure) level as well as the pump flow rate can be adjusted according to the supply air pressure.
- Vacuum gauges and pressure gauges for a direct reading of the vacuum and pressure at the application.
- Vacuum gauges for controlling the clogging level of the PS pump filters.

All our pneumatic suction and blowing pumps can be combined regardless of their suction and blowing flow rate and can be installed inside the system cabinet. Given the enormous number of possible combinations, this catalogue only describes combinations of pumps with the same size.

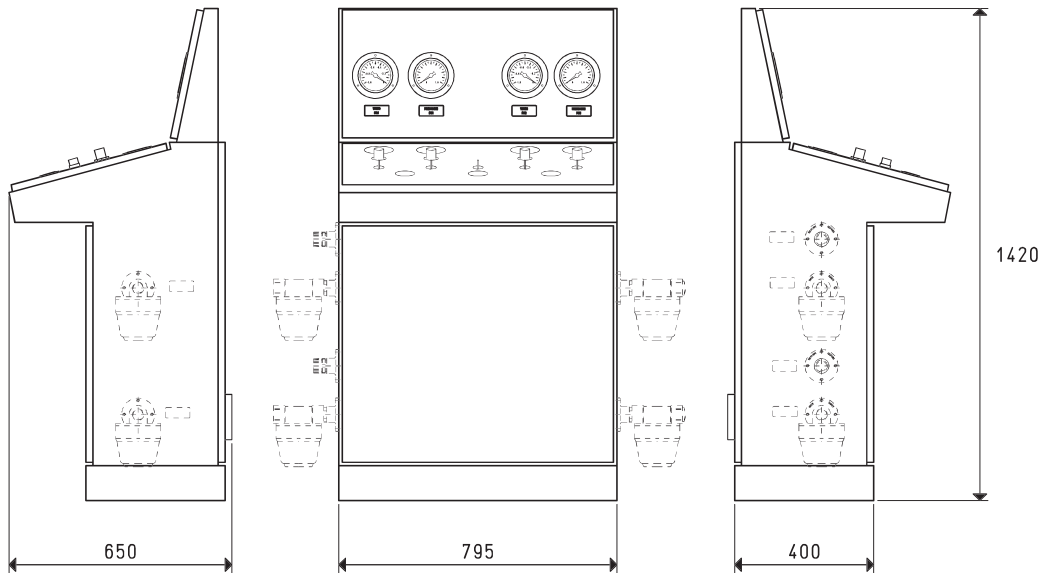

Item	Fitted for:	Weight Kg
AS 4	4 PA / PS pumps	120

NOTE: The filters are not parts built into the system, but they are the same filters installed on the PA / PS pumps, carried outside the cabinet.

To order the complete system, simply add the item of the selected PA and PS pumps to item AS 4.

Example: 1 AS 4

1 PA 100 1 PS 140

1 PA 170 1 PS 200

It is possible to install maximum 4 pumps on the system, regardless of their size and suction or blowing function.

NOTE: Vacuum generator supply must be carried out with non-lubricated compressed air, 5 micron filtration, in accordance with standard ISO 8573-1 class 4.

Transformation ratio: N (newton) = Kg x 9.81 (force of gravity)

inch = $\frac{\text{mm}}{25.4}$; pounds = $\frac{\text{g}}{453.6} = \frac{\text{Kg}}{0.4536}$

PNEUMATIC SUCTION AND BLOWING PUMP HOLDING SUPPORTS



The supports described on this page have been designed to allow a quick assembly of the pneumatic suction and blowing pumps and their easy placement on the machine. They are made with a sturdy, satin-finished, stainless sheet steel and are equipped with anti-slip and anti-vibration rubber feet. These supports are currently available for single pneumatic pumps and for the combined ones.



3D drawings are available on vuototecnica.net

SUPPORT FOR SMALL COMBINED PNEUMATIC PUMPS

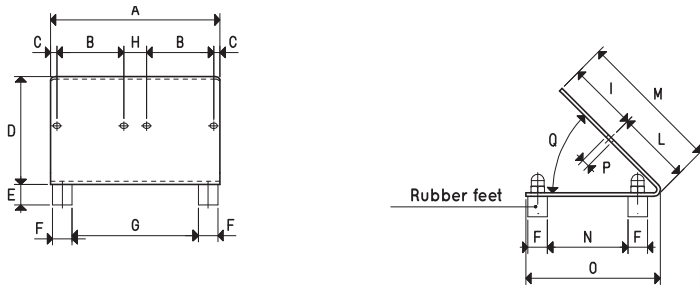

Item	A	B	C	D	E	F	G	H	I	L	M	N	O	P	Q	Weight Kg
GR DIV 03	100	39.5	3.75	64	12	11.5	74.5	13.5	41	43	84	47.5	79	4.5	45°	0.1

SUPPORT FOR SINGLE PNEUMATIC PUMPS

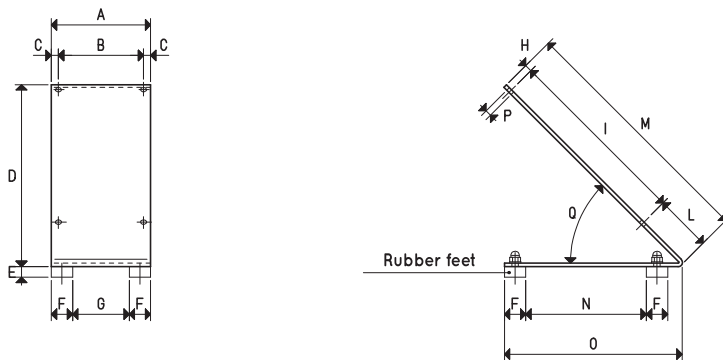

SUPPORT FOR COMBINED PNEUMATIC PUMPS

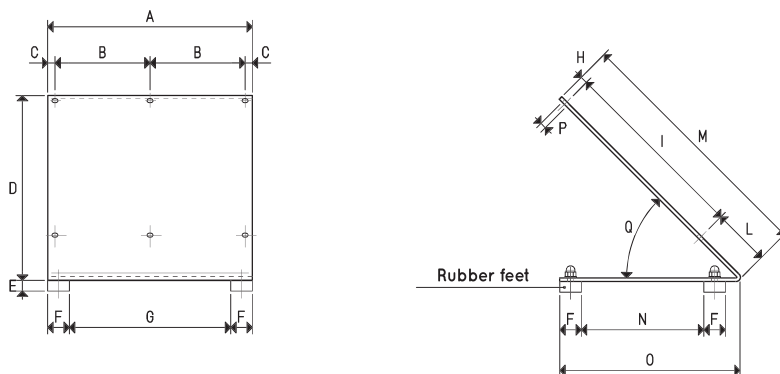

Item	A	B	C	D	E	F	G	H	I	L	M	N	O	P	Q	Weight Kg
GR DIV 01	140	120	10	270	15	30	80	10	264	81	355	170	250	8.5	45°	2.1
GR DIV 02	284	132	10	270	15	30	224	10	264	81	355	170	250	8.5	45°	4.2

Transformation ratio: N (newton) = Kg x 9.81 (force of gravity)

$$\text{inch} = \frac{\text{mm}}{25.4}; \text{pounds} = \frac{\text{g}}{453.6} = \frac{\text{Kg}}{0.4536}$$



PNEUMATIC SUCTION AND BLOWING PUMP SUCTION FILTERS

To allow the pneumatic suction and blowing pumps to work even in very dusty environments, it is necessary to use these filters that, installed on the suction inlet connection, can keep the finest dust and impurities and affecting the flow rate in a negligible manner.

The filtering cartridges, in fact, are made with a special treated paper with a porosity level of 5 - 7 micron, and pleated to increase the filtering surface.

FCL filters are composed of a transparent Plexiglass cylindrical body inside of which is located the filtering cartridge locked by two anodised aluminium flanges that are kept in place by Seeger rings, inside of which the threaded connectors and the seals are housed.

The filters can be inspected by simply removing one of the two flanges.

The container of the filtering element FP is made with plastic and it is screwed onto the blue plastic lid; a gasket located between the two elements ensures a perfect seal.

The container of the filtering element FC, as well as its lid, are made with sheet steel and varnished with a special oxidation-resistant treatment. A seal between the lid and the container ensures a perfect vacuum seal, while the release clamps on the container allow a quick opening of the lid to check or replace the filtering cartridge.

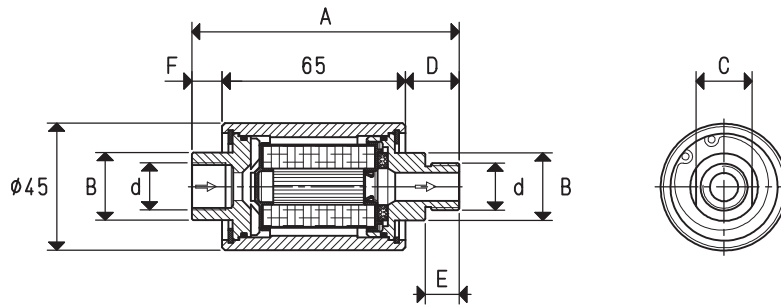

Item	d Ø	A	B Ø	C	D	E	F	Max capac. m³/h	For pumps item	Weight Kg	Spare cartridge item
FCL 1 MF	G1/4"	91.2	20	17	19.1	12	7.1	5	PA - PS 3	0.12	00 FCL 03
FCL 2 MF	G3/8"	93.4	24	20	19.1	12	9.3	20	PA - PS 7 - 14 - 18	0.14	00 FCL 03

Item FP 30 / 4 / SP

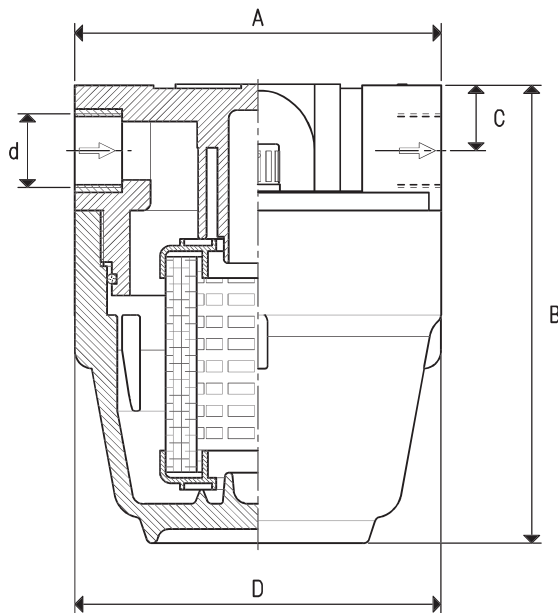

Item FC 38
Item FC 55

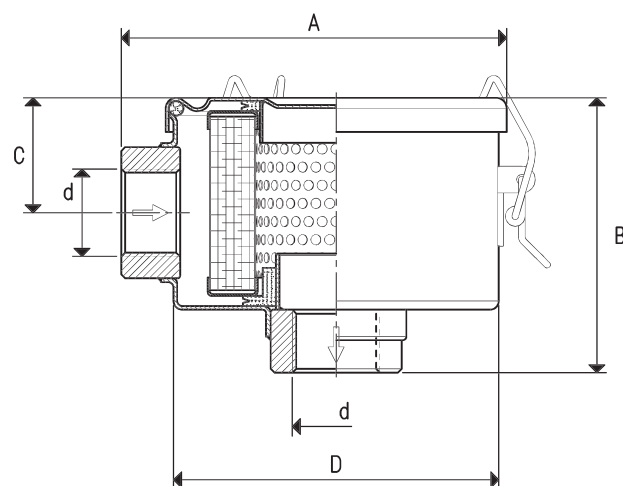

Item	d Ø	A	B	C	D Ø	Max capac. m³/h	For pumps item	Weight Kg	Spare cartridge item
FP 30/4/SP	G1"	145	169	24	130	100	PA - PS 40 ÷ 100	1.00	SP/4
FC 38	G1" 1/2	143	101	45	120	200	PA - PS 140 ÷ 200	0.95	00 FC 15
FC 55	G2"	143	170	79	120	300	PA - PS 250 ÷ 300	1.29	00 FC 33

Transformation ratio: N (newton) = Kg x 9.81 (force of gravity)

inch = $\frac{\text{mm}}{25.4}$; pounds = $\frac{\text{g}}{453.6} = \frac{\text{Kg}}{0.4536}$



Vacuum gauge Ø 40 mm with 1/8" coaxial gas coupler

Item	For pneumatic pumps
09 03 15	PA - PS 40 ÷ 300



Pressure gauge Ø 40 mm with 1/8" coaxial gas coupler

Item	bar	For pneumatic pumps
09 03 25	1 ÷ 10	All
09 03 20	1 ÷ 1.6	PS 40 ÷ 300



1/8" gas pressure reducer

Item	For pneumatic pumps
FIR 00 SF	PA 3 - 7 - 10 - 14 - 18 PS 3 - 7 - 10 - 14 - 18



1/2" gas filter/pressure reducer

Item	For pneumatic pumps
FIR 03	PA 40 - 70 - 100 - 140 - 170 - 200 - 250 - 300 PS 40 - 70 - 100 - 140 - 170 - 200 - 250 - 300





Sealing kit and reed valves

Item	For pneumatic pumps item
00 KIT M 3	PA 3 - PS 3
00 KIT M 7	PA 7 - PS 7
00 KIT M 10	PA 10 - PS 10
00 KIT M 14	PA 14 - PS 14
00 KIT M 18	PA 18 - PS 18



Sealing kit and reed valves

Item	For pneumatic pumps item
00 KIT PVP 40 M	PA 40 - PS 40
00 KIT PVP 70 M	PA 70 - PS 70
00 KIT PVP 100 M	PA 100 - PS 100
00 KIT PVP 140 M	PA 140 - PS 140
00 KIT PVP 170 M	PA 170 - PS 170
00 KIT PVP 200 M	PA 200 - PS 200
00 KIT PVP 250 M	PA 250 - PS 250
00 KIT PVP 300 M	PA 300 - PS 300

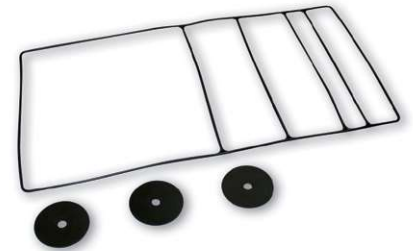

Exhaust silencers SSX

Item	For pneumatic pumps
SSX 1/4"	PA 3
SSX 3/8"	PA 7 - 10 - 14
SSX 1/2"	PA 18



Sound absorbing material on the exhaust

Item	For pneumatic pumps item	Quantity
00 15 110	PA 40 - PS 40	1 piece
	PA 70 - PS 70	1 piece
	PA 100 - PS 100	1 piece
	PA 140 - PS 140	1 piece
	PA 170 - PS 170	1 piece
	PA 200 - PS 200	1 piece
	PA 250 - PS 250	1 piece
	PA 300 - PS 300	1 piece



Sound absorbing material on ejectors

Item	For pneumatic pumps item	Quantity
00 15 111	PA 40 - PS 40	1 piece
	PA 70 - PS 70	1 piece
	PA 100 - PS 100	1 piece
	PA 140 - PS 140	2 pieces
	PA 170 - PS 170	2 pieces
	PA 200 - PS 200	2 pieces
	PA 250 - PS 250	3 pieces
	PA 300 - PS 300	3 pieces



VACUUM CYLINDERS

The cylinders described on this page are vacuum operated. By creating a vacuum in the anterior chamber of the cylinder, the piston's integrated rod protrudes, overcoming the opposing spring force. The piston is pushed by the air at atmospheric pressure that gets into the cylinder's rear chamber through the hollow stem.

The greater the pressure differential between the front chamber under vacuum and the rear chamber at atmospheric pressure, and the larger the piston thrust force will be.

The stem returns into position in two ways:

1) By preventing the atmospheric air from entering through the stem hole and with the vacuum inserted, the pressure differential inside the cylinder is removed. Under this condition, the thrust spring and the atmospheric pressure forces prevail on the stem which is thus pushed into its initial position.

2) By excluding the vacuum, the atmospheric pressure is restored in both the cylinder chambers. Also in this case, being the pressure differential removed, the stem returns to its initial position pushed by the thrust spring.

The first of these two methods is the true operating principle for which this cylinder has been designed. When a vacuum is created, in fact, a vacuum cup mounted on the stem of the perforated cylinder will be brought rapidly into contact with the object to be taken. The object is then automatically lifted and remain gripped during the whole time the vacuum stays engaged.

Because of this feature, vacuum cylinders associated with vacuum cups are recommended for gripping and handling machined, moulded or thermoformed objects, as well as for separating sheets of paper or plastic, sheet steel, etc. and lifting printed circuits or thin plastic panels. The advantages offered by these vacuum cylinders include: short, fast quick cycles controlled by a single vacuum interception valve, automatic compensation of the height of the objects to be gripped with no compression on them, non-rotating piston and extremely easy fixing.

They are fully made with anodised aluminium and are equipped with a special self-lubricating technopolymer bush which guarantees long duration.

Caution:

during the vacuum cup assembly phase, use the wr.3 seat as a contrast and not the wr.1 seat to avoid damaging the product.

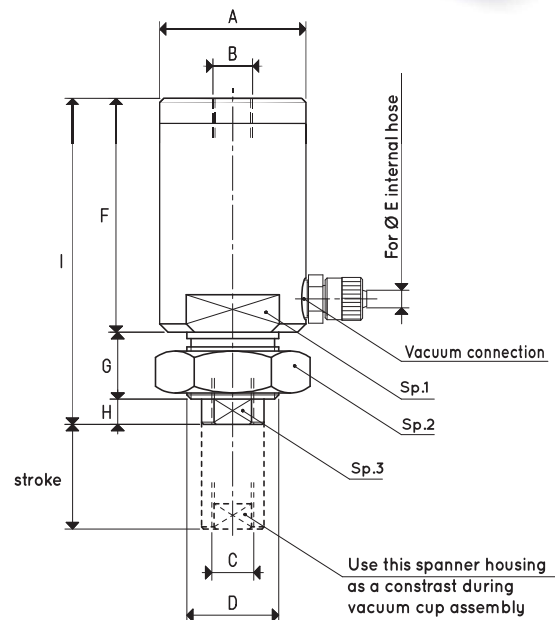

Item		25 05 10	25 10 10	25 15 10
Stroke	mm	17	25	30
Thrust force at -KPa 80	Kg	2.0	4.3	12.0
Lifting force at -KPa 80	Kg	0.45	1.0	2.5
Minimum cycle time	sec	0.3	0.4	0.6
Minimum level of vacuum	-KPa	60	60	60
Minimum necessary flow rate	NI/l'	15	30	90
Operating temperature	°C	5 ÷ 80	5 ÷ 80	5 ÷ 80
Weight	g	55	145	515
A	∅	24	35	59
B	∅	M 6	G1/8"	M 10
C	∅	M 5	G1/8"	G1/4"
D	∅	M 16 x 1.5	M 22 x 1.5	M 40 x 1.5
E Vacuum connection by tube	∅ int.	4	4	4
F		39.5	56	66
G		12	16	17
H		4	6	9
I		55.5	78	92
wr. 1		19	27	50
wr. 2		24	32	55
wr. 3		8	12	17



DISC CUPS

Apart from some standard rubber discs, these items are generally produced upon specific request by the client and for a minimum amount to be specified in the offer phase.

They can be die-cut from sheets or moulded in nitrile rubber, in natural para rubber, silicon or special compounds, as well as in rubberised or polyurethane fabric.

The discs described above are used in the printing industry, as an alternative to vacuum cups, for gripping and handling sheets of paper, cardboard or plastic.

3D drawings are available on vuototecnica.net

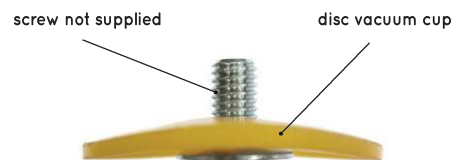
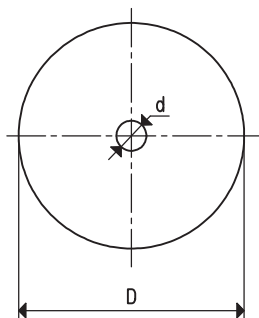

EXAMPLE OF APPLICATION

Item	D Ø	d Ø	S
01 17 31 N	17	3.5	0.8
01 30 41 NG	30	4.0	1.5
01 30 91 N	30	9.0	1.5
01 57 81 S	57	8.5	1.3

N = natural para rubber; NG= yellow rubber; S = silicon